

RTS STRIKER

Automatic Transmission Shifter



RTS-SFT611323
Suit 2 & 3 Speed Transmissions

www.racetranssolutions.com.au

Table of Contents

Installation Instructions	3-4
Shifter Mounting & Cable Connections	5
Shifter Cable Instructions	6
Ford C4, C5 & C6	7
Chrysler 727 & 904	8
GM T350 & T400	9
Powerglide	10
Parts Identification	11

RTS STRIKER INSTALLATION INSTRUCTIONS

IMPORTANT NOTICE

PLEASE READ THESE INSTRUCTIONS IN FULL PRIOR TO STARTING TO INSTALL SHIFTER. ONLY PERSONS WHO ARE CONFIDENT IN DISSASSEMBLING A VEHICLE AND INSTALLING THIS SHIFTER SHOULD ATTEMPT IT. A TRAINED AUTOMOTIVE TECHNICIAN IS RECOMMENDED TO INSTALL THIS SHIFTER.

For safety , be sure to read these instructions in full prior to starting to install this shifter.
Only persons who are confident in disassembling a vehicle and installing this shifter should attempt it.
A trained automotive technician is recommended to install this shifter into a vehicle.

WARNING: MAKE SURE VEHICLE IS PLACED ON JACK STANDS PRIOR TO WORKING ON INSTALLING THIS PRODUCT.
DANGER: DO NOT WORK ON OR UNDER VEHICLE IF SUPPORTED BY THE LIFTING JACK ONLY.
CAUTION: FAILURE TO OBSERVE THESE WARNINGS COULD RESULT IN DEATH OR INJURY.

THE USE OF EYE PROTECTION IS ADVISED WHEN INSTALLING THIS PRODUCT



This kit contains the following parts

- 1x Striker Shifter Mechanism**
- 1x Shifter Cover**
- 1x Heavy Duty 5ft Shifter Cable**
- 1x Mounting Hardware Kit**
- 1x 3 Speed Shifter Plate**
- 1x 2 Speed Shifter Plate**
- 1x Transmission Bracket Kit**
- 1x Powerglide Installation Kit**

The RTS striker shifter comes with the forward pattern gates for 2 & 3 speed transmissions. Reverse pattern valve bodies will require optional shift gates. This shifter is supplied with the optional trans brake /line lock switch. The bung can be removed and the switch installed easily. We recommend this be done prior to mounting the shifter to the vehicle.

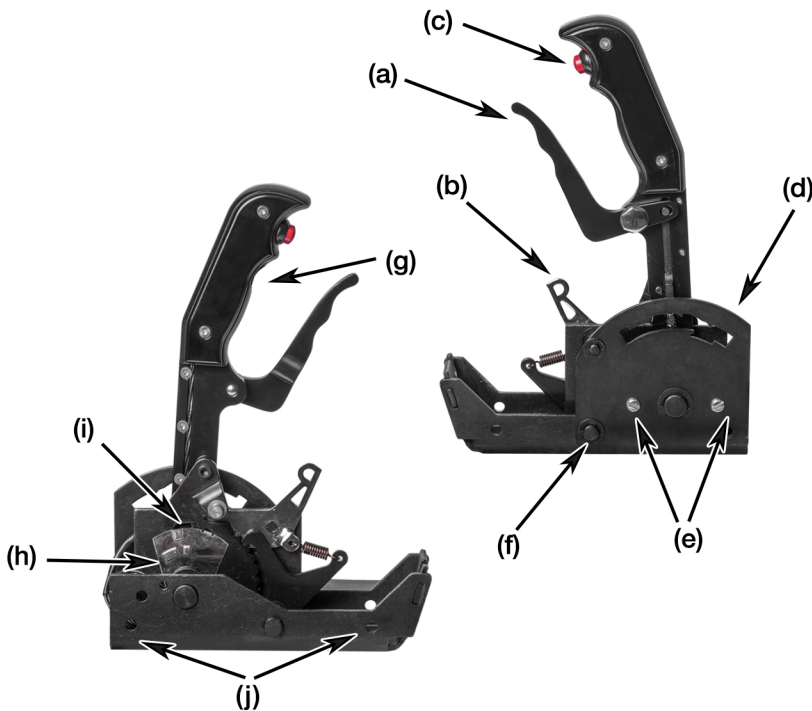

- (a) Shift gate lever.
- (b) Reverse lever
- (c) Electrical switch for trans brake or nitrous
- (d) Shift gate
- (e) Shift gate screws
- (f) E clip

- (g) Auxillary switch position
- (h) Park / neutral cam
- (i) Reverse cam
- (j) Cover pin holes

Preparing Vehicle for Installation

To Install this shifter , the vehicle will be required to be off the ground and on jack stands , ramps or vehicle hoist. Do not work on or under a vehicle supported on a jack only . Make sure the vehicle is off the ground enough to work under it safely.

Step 1

Place transmission in Park position. Remove old shifter linkages from transmission and disconnect vehicle shifter. Remove console if fitted , this may require modification to fit the new shifter. Some vehicles have a gear lever locking mechanism in the steering colum and this will need to be disabled.

Step 2

Mark where the new shifter is to be mounted and drill the 4 holes using a 9/32 drill bit . Make sure there are no wiring or components under the floor where you are drilling.

Step 3

Mark and drill a 1" hole no closer than 3" in front of the shifter . This is for the cable to go through the body and to the transmission. Make sure there are no wiring or components under the floor where you are drilling.



Note : make sure the shifter has clearance to dashboard and seats when moving through all the gears. Check this prior to drilling holes or mounting shifter

Ensure the floor is strong enough to support the shifter. A strengthening plate may be required on some vehicles.

Shifter Mounting & Cable Connections

Step 1

- Make sure the correct gate plate is installed on the shifter to suit your transmission.

This can be changed by removing the 3 E clips (a) and 2 screws (b).

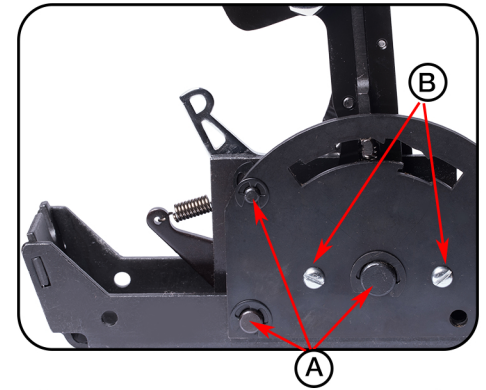

Step 2

- Remove the lock nut and dust boots from cable.



Step 3

- Undo the 7/16 lock nut and washer from cable and screw the bulkhead adaptor onto the cable thread (c). Replace the dust boot onto the cable and screw the cable eyelet and lock nut onto the cable and tighten.

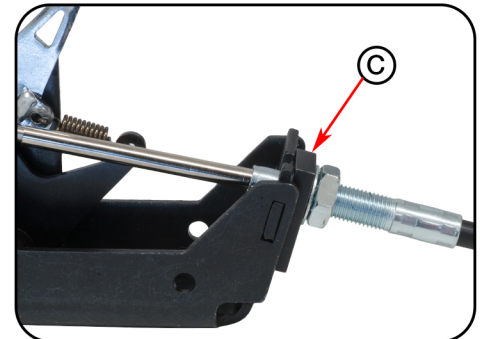

Step 4

- Place the eyelet onto shifter and secure with the E clip (d). Use the 1/4" -20 x 1/2 bolt to lock the bulkhead adaptor to the shifter and tighten (e).

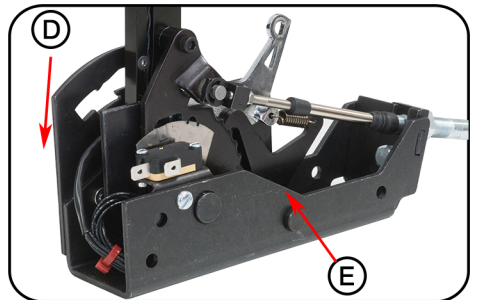

Step 5

- Mount the neutral safety switch (f) to the bracket and secure with the supplied screws, washers and nuts (g). (warning, do not overtighten or damage to the switch will occur) .If reverse lamps are required, then place this switch (h) on top and longer screws (not supplied) will be needed.

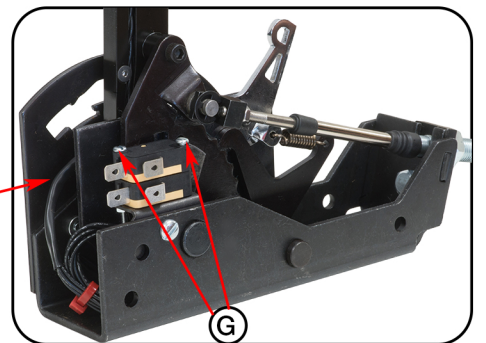

Step 6

- If using the second switch in the shifter handle, then this will need to be installed at this time. Remove the bung from the handle and insert wire and switch.

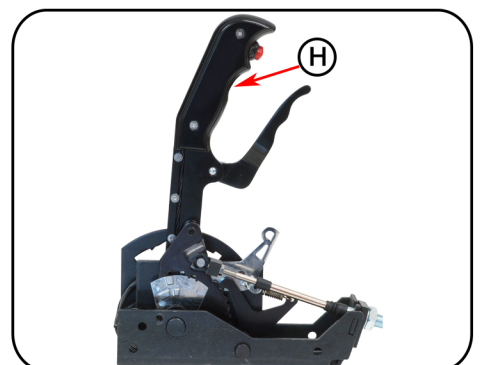

Step 7

- Push cable through the hole in floor pan and mount shifter using the 4 x 1/4" -20 x 1-1/2 bolts, washers and nuts. (H)

Shifter Cable Instructions

Note 1

- When installing the cable to the transmission make sure there are no tight bends. This will effect the operation of the shifter and cause parts to bend or fail.

If the cable is longer than needed then loop it above the transmission making sure the cable is away from the exhaust . Make sure cable is away from the tail shaft and not hanging below the vehicle .

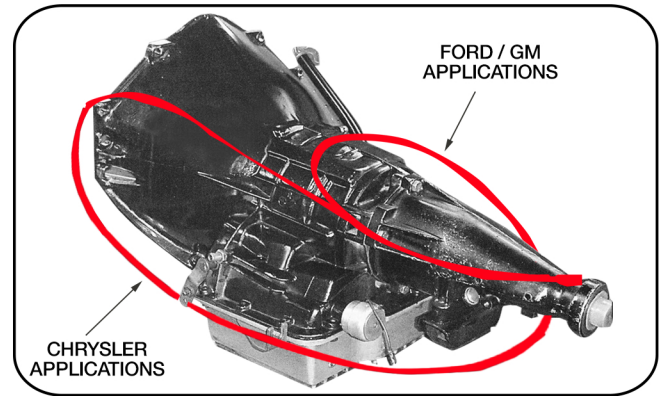

Note 2

- Ensure the cable exits the shifter and has at least 3 inches before it goes through the floor. This will make sure the bend radius will not cause problems with the shifter.

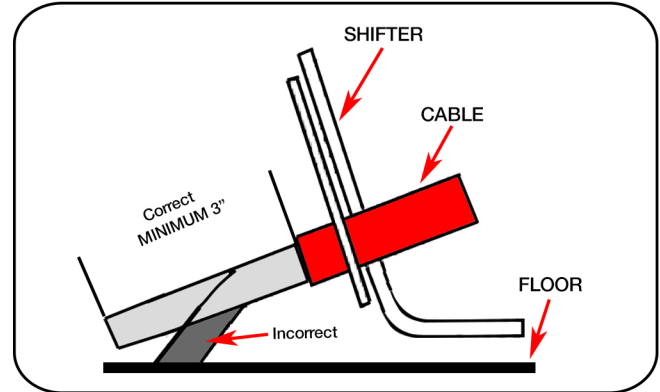

Note 3

- Make sure the cable swivel is attached to the correct hole in the lever plate. If it is in the incorrect hole then damage can occur to the shifter, cable and transmission.



Note 4

- Make sure there is sufficient room between the cable and exhaust. A shield may be needed to stop the heat causing damage to the cable. It not recommended to wrap the cable as trapped heat can cause problems.

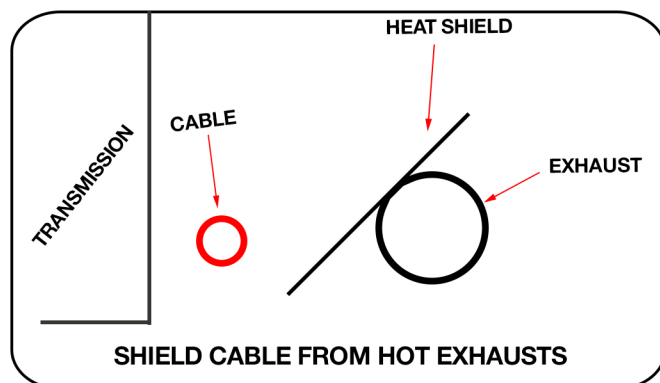

Note 5

- Adjustment of the cable is crucial to the performance of the shifter. The swivel should slide in and out of the lever without tension when in park and low gear. Always check the alignment and adjustment through all the gears prior to starting the vehicle. Fine tuning the cable will then lead to years of perfect operation of the RTS shifter.

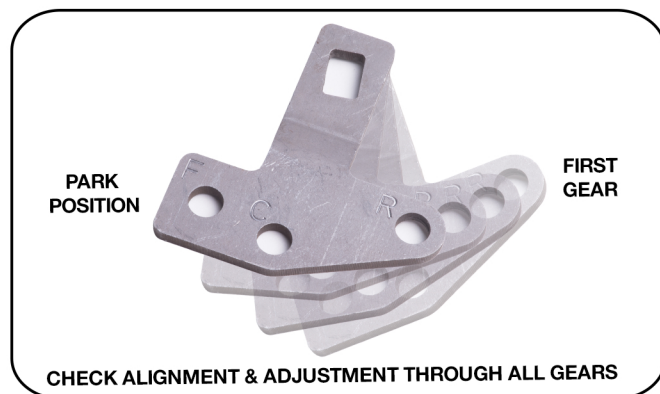

Ford C4, C5 & C6

Step 1

- Remove the nut and lock washer and remove the down shift linkage from the selector shaft (a). This is the outer linkage. If equipped with the inhibitor switch then unbolt and slide off the shaft (b).

Step 2

- Install the new selector arm (c) onto the shaft. If the original shift lever faces the down position, then it will need to be cut to clear the new arm.

Step 3

- Make sure the arm faces down when the gear selector moves equally from park to 1st. tighten the new arm and check operation is smooth. Reinstall the downshift lever and re install the nut and washer, check the operation is smooth.

(C4 & C5) Remove the 2 lower bolts from the servo cover and install shift bracket (e). Do not over tighten.

(C6) Remove 2 pan bolts from left rear corner of the fluid pan. Attach bracket (f) using the 2 spacers (not required with cast pans) using the 2 x 1" bolts supplied and tighten up to 13lbs-ft. Note: do not over tighten these bolts.

Step 4

- Remove the rubber dust seals and mounting nut and washer from cable. Slide cable through bracket and replace washer and nut until cable sits 1/2 way in bracket. Place dust seals on cable and Position cable without kinks and away from exhaust with no tight bends.

Step 5

- Screw the cable adaptor on the threaded cable end and lock with cable nut. This adaptor fits in the shifter bracket hole.

Step 6

- Move the shifter into the low position and adjust the cable swivel so that they align with the hole in the selector bracket. Move the shifter to the Park position and move the selector bracket to the park position, check the alignment and adjust the cable as necessary. Install split pin once in the final position.

WARNING, DO NOT FORCE SHIFTER AS DAMAGE WILL OCCUR

Step 7

Rewire the start/ neutral switch (If required) to the switch on the shifter using the wiring on the old switch removed from the transmission. Some Ford vehicles have the inhibitor switch on the steering column. In some cases, the use of a relay may be necessary. If a reverse switch is required, then this can be ordered.

The reverse switch must sit above the start / neutral switch. When testing the operation of this switch, make sure both foot and hand brake are applied to make sure vehicle doesn't launch forward.

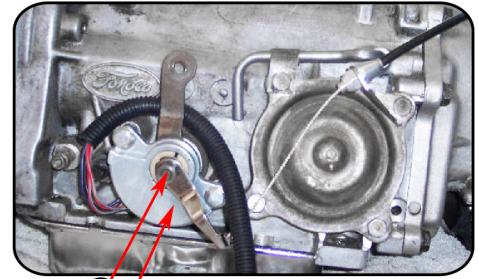

(A) (B)

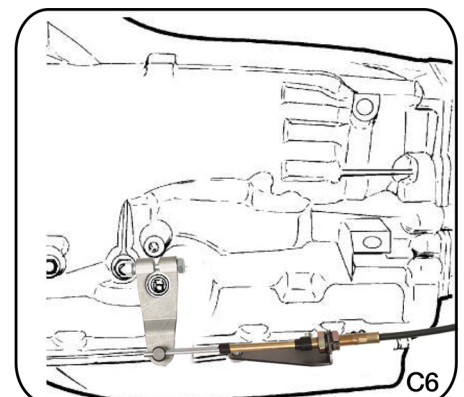
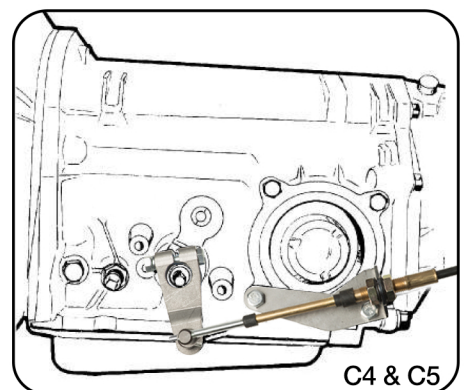
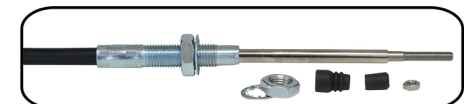
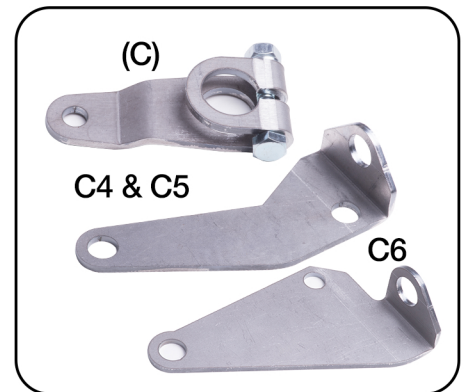
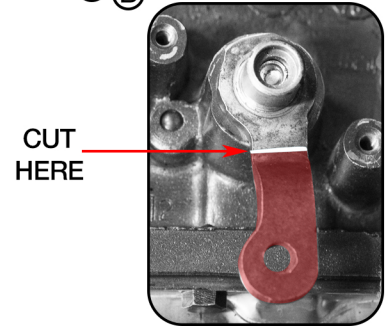

Shifter Instructions for Chrysler 727 & 904

Step 1

- Loosen and remove the kick down from the small shaft (a). Remove the shifter linkage bracket from larger part of shaft (b).

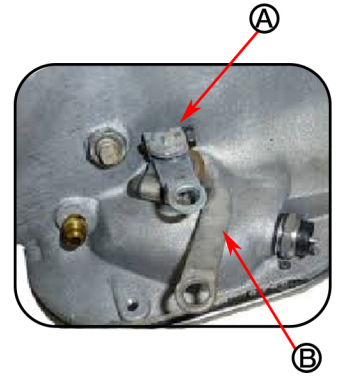

Step 2

- Place replacement lever onto shaft making sure not to bind it against transmission (c). Check for smooth operation of lever and tighten bolt.

Replace the kick down linkage to the small part of the shaft and tighten.

Step 3

- Remove the 2 transmission pan bolts under the selector and mount the supplied bracket with the spacers. (The spacers are only used on transmission with a stamped pan). Cast pans do not need spacers. Install with the 1" bolts supplied in the kit and tighten to 13ft-lbs (d).

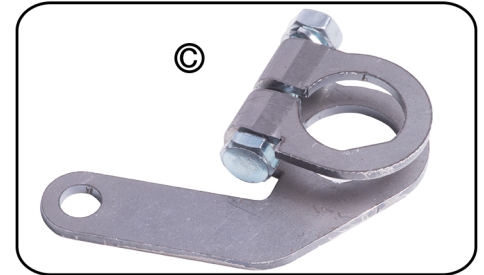

Step 4

- Route the shifter cable with liner angles and no sharp bends. Ensure to keep cable away from exhaust pipes. If the pipes are close and shield or thermal cover may be required to avoid damage to cable. Remove rubber grommets and locking nut with washer and install cable into bracket. Replace washer and locking nut and adjust to half way. Replace grommets and insert the cable swivel into the selector bracket front hole.

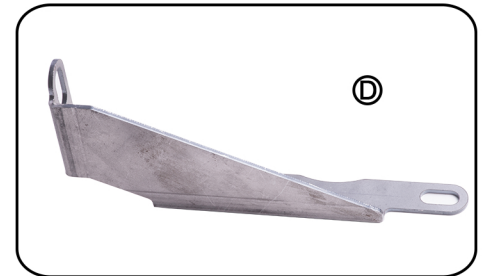

Step 5

- Place shifter into 1st gear and move selector bracket into 1st gear. Adjust the cable nuts forward or back until the cable swivel moves freely into the selector bracket hole.

Try the shifter in all positions to ensure all gears are selected and the cable swivel is easily moved in and out of the selector bracket in each gear. When this is done place split pin in position and bend legs out.



WARNING, DO NOT FORCE SHIFTER AS DAMAGE WILL OCCUR

With the Chrysler transmission, the shifter will have a shorter distance to move into park compared to a GM transmission. There is no need to force the shifter into Park as damage will occur.

The shifter switches will work on early cars and will not need to be wired as the original switch on the transmission will function perfectly. Some later vehicles may need the switches wired.

Shifter Instructions for GM T350 & T400

Step 1

- Remove the stock shift lever from the transmission and replace with supplied GM selector (a). Reuse the selector nut and tighten to 23ft lbs. Move lever back and forward to ensure smooth operation.

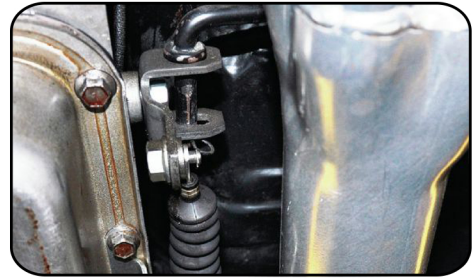

Step 2

- Remove the 2 middle transmission pan bolts and mount the supplied bracket with the spacers. (The spacers are only used on T400 with stamped pan). Cast pans do not need spacers but may have to modify bracket slightly. Ensure the correct holes are used for the transmission you have in the vehicle.

Step 3

- Route the shifter cable with liner angles and no sharp bends. Ensure to keep cable away from exhaust pipes. If the pipes are close and shield or thermal cover may be required to avoid damage to cable. Remove rubber grommets and locking nut with washer and install cable into bracket. Replace washer and locking nut and adjust to half way. Replace grommets and insert the cable swivel into the selector bracket front hole.



Step 4

Place shifter into 1st gear and move selector bracket into 1st gear . Adjust the cable nuts forward or back until the cable swivel moves freely into the selector bracket hole. Try this again with the shifter in the park position and the selector in the park position . Small adjustments may be necessary and retry in 1st gear again.

- Try the shifter in all positions to ensure all gears are selected and the cable swivel is easily moved in and out of the selector bracket in each gear. When this is done place split pin in position and bend legs out .

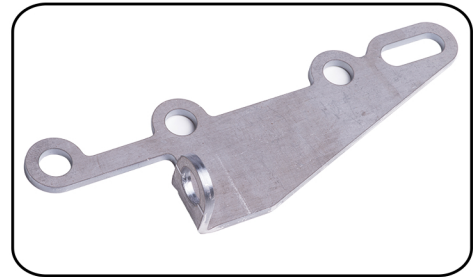

WARNING, DO NOT FORCE SHIFTER AS DAMAGE WILL OCCUR

Rewire the start/ neutral switch (usually purple wires) to the switch on the shifter. In some cases, the use of a relay may be necessary. If a reverse switch is required, then this can be ordered. The reverse switch must sit above the start / neutral switch. When testing the operation of this switch, make sure both foot and hand brake are applied to make sure vehicle doesn't launch forward.

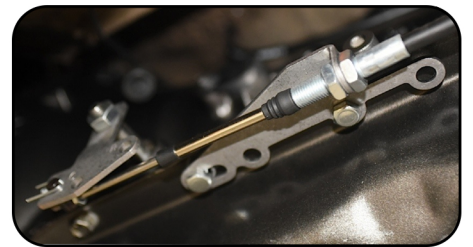

Ensure any gear safety mechanism is disconnected inside the steering column. This may stop the vehicle selecting the crank position while the vehicle is not in the park

Shifter Instructions for Powerglide

Step 1

- Remove the stock kick down linkage and discard shift lever from the transmission. Replace with supplied GM selector. Reuse the selector nut and tighten to 23ft lbs. move lever back and forward to ensure smooth operation.

Step 2

- When transmission is cool , drain fluid from pan. A pry bar may be required to break the seal.

Step 3

- Remove the two bolts holding the manual valve guide plate. Unhook the detent roller spring noting how it is attached to groove in the valve. Let the arm pivot out of the way.

Step 4

- Loosen the pinch bolt and slide lever shaft out of the transmission and discard. A lever will help pry it off the shaft. Place the new 2 piece shaft and bracket into the housing aligning the flat on the shaft with the lever. Make sure the bracket is facing down and re tighten pinch bolt.

Step 5

- Make sure the pin on the selector lever is in place as you install the manual valve guide plate . Tighten the 2 bolts on the guide plate to 15lbs and then install the detent roller spring making sure the lever moves freely from park to 1st gear with the detent for each gear.

Step 6

- Replace the pan once it has ben cleaned and a new gasket installed. Install the new cable bracket and tighten all bolts to 8lbs.

Step 7

- Route the shifter cable with linier angles and no sharp bends. Ensure to keep cable away from exhaust pipes. If the pipes are close and shield or thermal cover may be required to avoid damage to cable. Remove rubber grommets and locking nut with washer and Install cable into bracket. Replace washer and locking nut and adjust to half way. Replace grommets and insert the cable swivel into the selector bracket hole marked with H.

Step 8

Place shifter into 1st gear and move selector bracket into 1st gear. Adjust the cable nuts forward or back until the cable swivel moves freely into the selector bracket hole. Try this again with the shifter in the park position and the selector in the park position. Small adjustments may be necessary and retry in 1st gear again.

Try the shifter is all positions to ensure all gears are selected and the cable swivel is easily moved in and out of the selector bracket in each gear. When this is done place split pin in position and bend legs out.

WARNING, DO NOT FORCE SHIFTER AS DAMAGE WILL OCCUR

Rewire the start/ neutral switch (usually purple wires) to the switch on the shifter. In some cases, the use of a relay may be necessary. If a reverse switch is required, then this can be ordered. The reverse switch must sit above the start / neutral switch. When testing the operation of this switch, make sure both foot and hand brake are applied to make sure vehicle doesn't launch forward.

Ensure any gear safety mechanism is disconnected inside the steering column. This may stop the vehicle selecting the crank position while the vehicle is not in the park /neutral position.

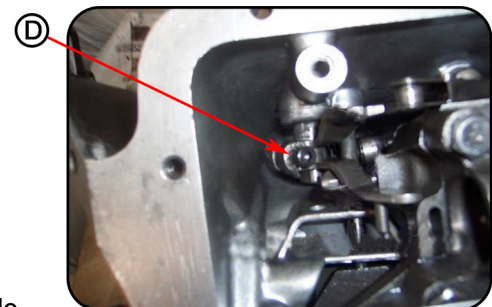
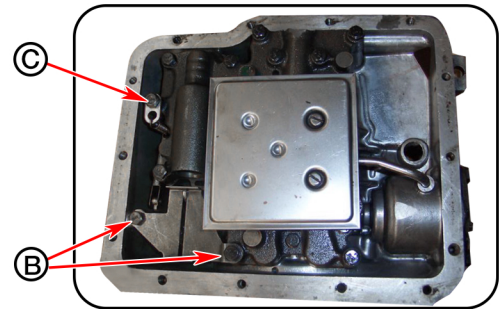
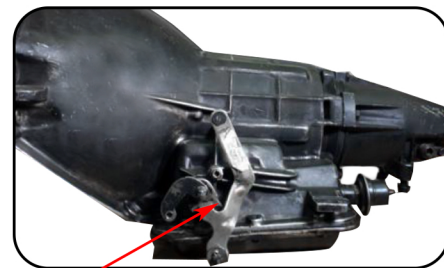

Parts Identification

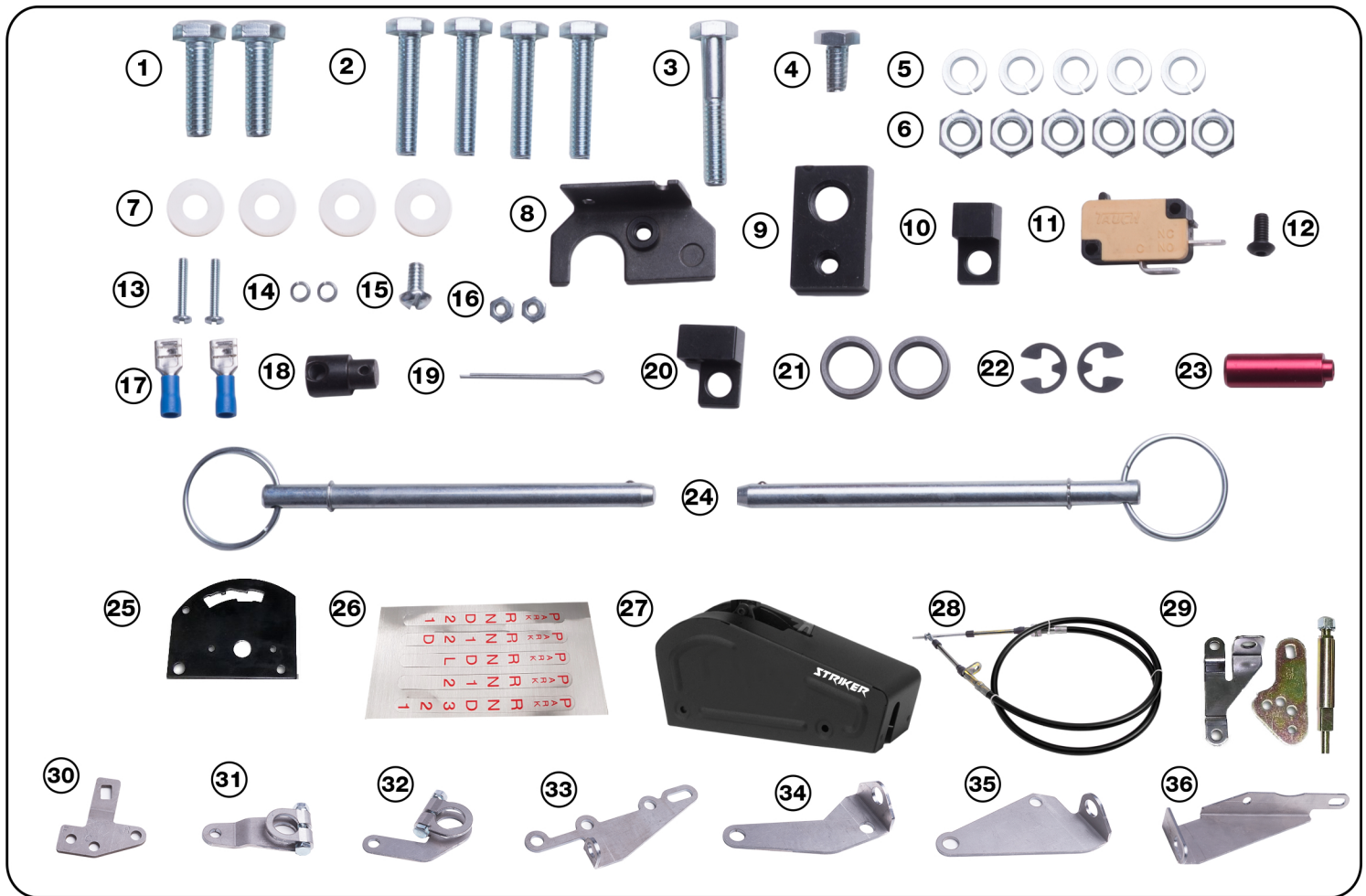

QTY	DESCRIPTION	FIGURE
2	5/16-18 x 1" hex bolt	1
4	1/4-20 x 1 -1/4" hex bolt	2
1	1/4-20 x 1-1/2 hex bolt	3
1	1/4-20 x 1/2" hex bolt	4
5	1/4 spring washers	5
6	1/4-20 nuts	6
3	Thin case spacers	7
1	Thick case spacer	7
1	Switch bracket	8
1	Cable bulkhead adaptor	9
1	Cable eyelet	10
1	Inhibitor Switch	11
1	Reverse lever screw	12
2	4-40 x 5/8 screws	13
2	4-40 Spring washer	14
1	10-24 x 1/2 Switch bracket screw	15
1	4-40 Nuts	16
1	Crimp terminals	17
1	Cable Swivel	18

QTY	DESCRIPTION	FIGURE
1	Split Pin	19
1	Cable eyeleft offset	20
2	Bracket spacers	21
1	E Clips	22
1	Red reverse lever	23
1	Cover pins	24
1	4 Speed Gate	25
1	Gear indicator decal sheet	26
1	Striker Cover	27
1	5ft cable	28
1	Powerglide Selector Kit	29
1	GM transmission lever	30
1	Ford transmission lever	31
1	Chrysler transmission lever	32
1	GM linkage bracket	33
1	C4/C5 linkage bracket	34
1	C6 linkage bracket	35
1	Chrysler linkage bracket	36



www.racetranssolutions.com.au